

SPECIFICATION



Product Name : LED Street Light

Part No: INUI-SE150W

Approval No : 20170320003

1.

Outlook:

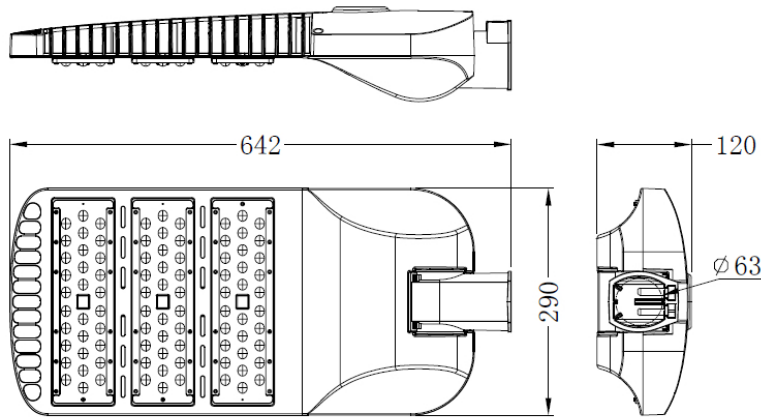

2. Application

Suitable for the street lighting at highways, urban roads and secondary roads, stadiums, sidewalks, residential areas, industrial areas, squares, parks, schools, villas, gardens and other places.

3. Features

- | Absolutely unique mold, make your lighting special and fantastic.
- | Perfect Light Distribution Solution: Adoption of integrated shell optic lens, enhance the brightness and illumination uniformity.
- | Anti-glare and uniform light level to avoid any visual discomfort.
- | Meanwell high quality power supply, input voltage 100-277V. The power efficiency is more than 97%, power factor greater than 0.98, UL compulsory certification.
- | Adopting PHILIPS 5050 led light sources and INUI LED lens technology, 8% light efficiency higher than the same type lights in the market, with higher light transmittance up to 98%.
- | Duct type thermal design, reduce the weight of the light and ensure good heat dissipation, lower luminous decay, and also extend life span of the leds. Adopting the popular CHEM modular design, effectively reduce the following maintenance cost.
- | Low energy consumption, matching high efficiency constant-current driver, 60% energy saving; with good resistance to over-current, over-voltage, lightning, high temperature, which fully ensure long life span and high stability of the products.
- | Durable lights with long life span up to 80000 hours; No need frequent replacements of lights and regular maintenance.
- | Green environmental protection, no UV light and infrared radiation, no mercury pollution.
- | Nice appearance and non-fouling properties, Protection class IP66.
- | Work without strobe, fast transient response; A wide range of working voltage.
- | 20-Kv Anti Surge Protection fitted.

4. Specification

Part NO	INUI-SE200150CW	INUI-SE200150WW	INUI-SE200150NW
Parameter			
Inptut voltage	AC90V~305V 50/60HZ //		DC12-24V
System consumption(W)	150	150	150
Luminous flux(lm)	24,750	24,500	24,300
Chip Brand	PHILIPS 5050	PHILIPS 5050	PHILIPS 5050
Beam Angle	150*65 DEG	150*65 DEG	150*65 DEG
CRI	>80		
Colour Temperature	Warm white:2700-3200K / Neutral white:4000-4500K / Pure white:5000-6500K		
LED Driver	MEAN WELL HLG-185H		
Luminous efficiency(lm/w)	> 160		
Lifespan(hrs)	>80000		
IP Rating	IP66		
Dimmable	YES&NO	YES&NO	YES&NO
Size(mm)	642x290x120	642x290x120	642x290x120
Net Weigh(kg)	8.0	8.0	8.0
Package Size(mm)	765*355*245	765*355*245	765*355*245
Package Quantity(Pcs)	1	1	1
Gross Weigh(kg)	8.3	8.3	8.3

5. Distribution Curve (150W)

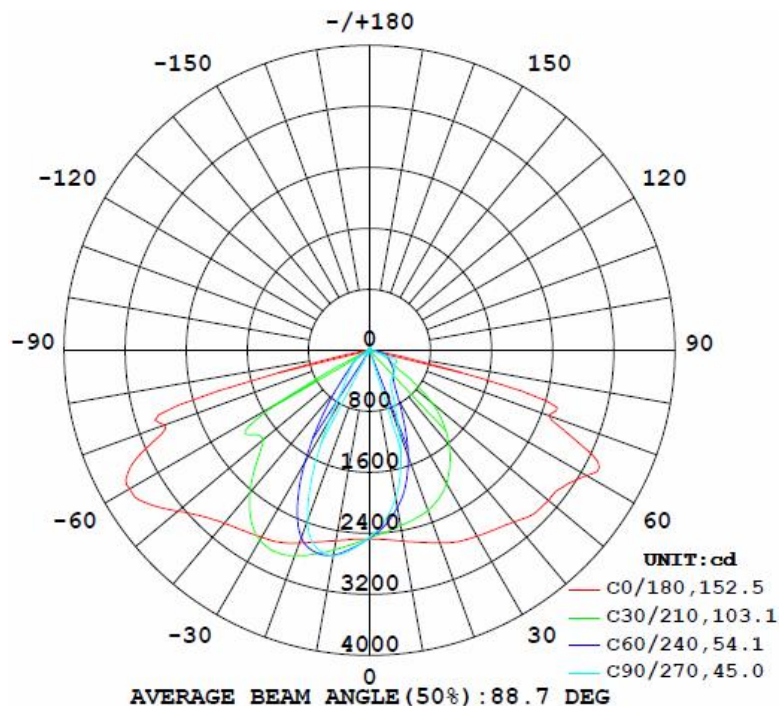

Light Distribution Type Options: Type I, Type II and Type III Available

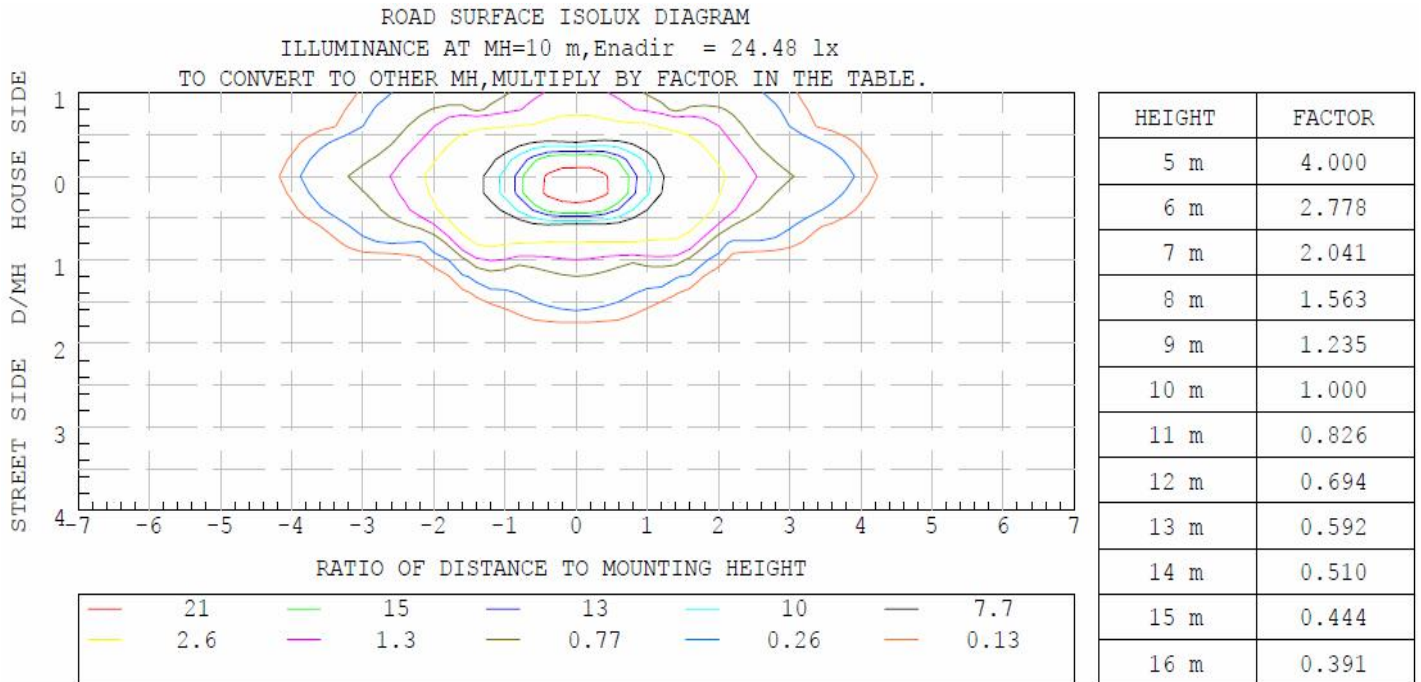

6. Operation and Storage Condition

- I Operation Ambient Temperature -40 to $+55^{\circ}\text{C}$, Relative Humidity 20~90%
- I Input Voltage 100~240V AC, 50/60Hz
- I Protection to IK08
- I Storage Ambient Temperature -20 to $+60^{\circ}\text{C}$, Relative Humidity 5~95%
- I Mounting Height : Suitable for 6~10m height

7. Package

Inner box Size: 645mm×295mm×135mm

(2 PCS LED Street Light)

Outer box Size: 745mm×395mm×225mm

8. Assembly and Installation

I Assembly-Electricity

1) AC100-240V

- Ø Blue : Neutral
- Ø Brown : Live
- Ø Yellow-Green : Ground



2) DC12-24V

- Ø Red : V+
- Ø Black:V-



9. Warning

- I Do Not Use Other Devices for LED Street Light ,Installation Such as Stabilizer, Regulator ...etc
- I Do Not Open the Light Engine
- I Do Not Soak the LED Street Light into Water
- I Do Not Light up the System Without Grounding



VERIFICATION OF EMC COMPLIANCE

Verification No.: EL-INL140300122202W
Applicant: INUI LIMITED
Address of Applicant: Unit 4 Beaumont Court, Prince William Road
Loughborough, Leicestershire LE11 5DA
Product Name: SE LED Light range
Product Description: LED Street Light
Model No.: SE-30, SE-40, SE-50, SE-60W, SE-80W, SE-100W, SE-120W, SE-150W

Sufficient samples of the product have been tested and found to be in conformity with
Test Standard: EN 55015:2013,
EN 61547:2009,
EN 61000-3-2:2006+A1:2009+A2:2009,
EN 61000-3-3:2013.

As shown in the

Test Report Number(s): SGS140300122202W

This verification of EMC Compliance has been granted to the applicant based on the results of the tests, performed by laboratory of SGS-CSTC Standards Technical Services Co., Ltd. on the sample of the above-mentioned product in accordance with the provisions of the relevant specific standards and Directive 2004/108/EC. The CE mark as shown below can be used, under the responsibility of the manufacturer, after completion of an EC Declaration of Conformity and compliance with all relevant EC Directives.



Richard Shaw
Manager

Date: 2015-04-30

Copyright of this verification is owned by SGS CSTC Standards Technical Services Co., Ltd and may not be reproduced other than in full and with the prior approval of the General Manager. This verification is subjected to the governance of the General Conditions of Services, printed overleaf.

Member of the SGS Group (SGS SA)